

Thyristor/Diode and Thyristor/Thyristor, 500A (SUPER MAGN-A-PAK Power Modules)



SUPER MAGN-A-PAK

FEATURES

- High voltage
- Electrically isolated by DBC ceramic (Al_2O_3)
- 3500 V_{RMS} isolating voltage
- Industrial standard package
- High surge capability
- Modules uses high voltage power thyristor/diodes in two basic configurations
- Simple mounting
- UL approved file E320098
- Compliant to RoHS
- Designed and qualified for multiple level

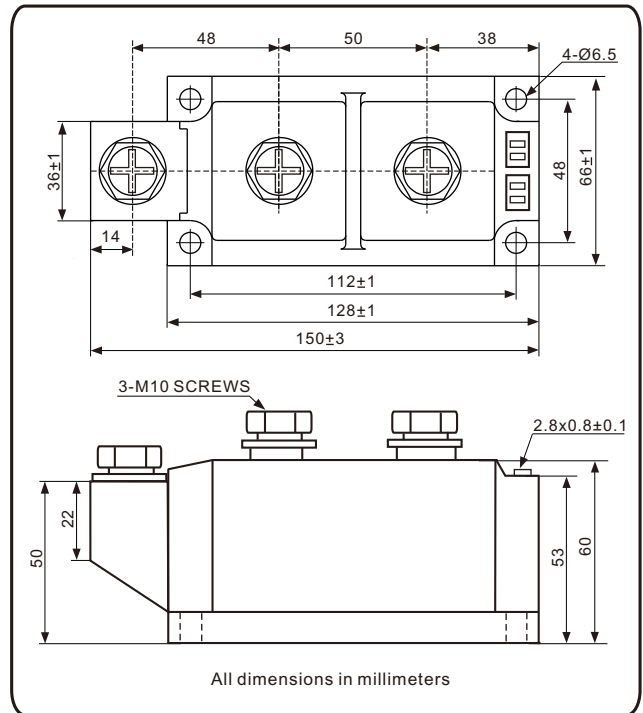

APPLICATIONS

- DC motor control and drives
- Battery charges
- Welders
- Power converters
- Lighting control
- Heat and temperature control
- Ups

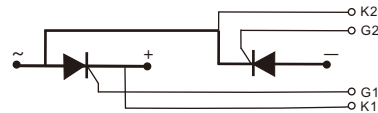

NKT

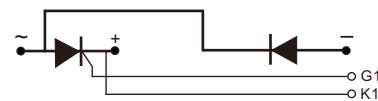

NKH

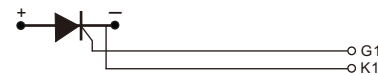

NKET

PRODUCT SUMMARY	
$I_{T(AV)}$	500 A

MAJOR RATINGS AND CHARACTERISTICS			
SYMBOL	CHARACTERISTICS	VALUE	UNITS
$I_{T(AV)}$	85 °C	500	A
$I_{T(RMS)}$	85 °C	785	A
I_{TSM}	50 Hz	16000	
	60 Hz	16800	
I^2t	50 Hz	1280	kA ² s
	60 Hz	1167	
$I^2\sqrt{t}$		12800	kA ² /√s
V_{DRM} / V_{RRM}	Range	400 to 1600	V
T_J	Range	-40 to 125	°C

ELECTRICAL SPECIFICATIONS

VOLTAGE RATINGS				
TYPE NUMBER	VOLTAGE CODE	V_{RRM}/V_{DRM} , MAXIMUM REPETITIVE PEAK REVERSE VOLTAGE V	V_{RSM}/V_{DSM} , MAXIMUM NON-REPETITIVE PEAK REVERSE VOLTAGE V	I_{RRM}/I_{DRM} AT 125 °C mA
NKT500 NKH500 NKET500	04	400	500	40
	08	800	900	
	10	1000	1100	
	12	1200	1300	
	14	1400	1500	
	16	1600	1700	

FORWARD CONDUCTION					
PARAMETER	SYMBOL	TEST CONDITIONS		VALUES	UNITS
Maximum average on-state current at case temperature	$I_{T(AV)}$	180° conduction, half sine wave ,50Hz		500	A
				85	°C
Maximum RMS on-state current	$I_{T(RMS)}$	180° conduction, half sine wave ,50Hz , $T_C = 85^\circ\text{C}$		785	A
Maximum peak, one-cycle, on-state non-repetitive surge current	I_{TSM}	t = 10 ms	No voltage reappplied	Sine half wave, initial $T_J = T_J$ maximum	16000
		t = 8.3 ms			16800
Maximum I^2t for fusing	I^2t	t = 10 ms	100% V_{RRM} reappplied		1280
		t = 8.3 ms			1167
		t = 10 ms	896		
		t = 8.3 ms	818		
Maximum $I^2\sqrt{t}$ for fusing	$I^2\sqrt{t}$	t = 0.1 ms to 10 ms, no voltage reappplied		12800	$\text{kA}^2\sqrt{\text{s}}$
Maximum on-state voltage drop	V_{TM}	$I_{TM} = 1500\text{A}$, $T_J = 25^\circ\text{C}$, 180° conduction		1.7	V
Maximum forward voltage drop	V_{FM}	$I_{FM} = 1500\text{A}$, $T_J = 25^\circ\text{C}$, 180° conduction		1.4	V
Maximum holding current	I_H	Anode supply = 12 V initial $I_T = 30\text{A}$, $T_J = 25^\circ\text{C}$		300	mA
Maximum latching current	I_L	Anode supply = 12 V resistive load = 1 Ω Gate pulse: 10 V, 100 μs , $T_J = 25^\circ\text{C}$		500	

SWITCHING					
PARAMETER	SYMBOL	TEST CONDITIONS		VALUES	UNITS
Typical delay time	t_d	$T_J = 25^\circ\text{C}$,gate current = 1A, $dI_g/dt = 1\text{A}/\mu\text{s}$		2	μs
Typical rise time	t_r	$V_d = 0.67 V_{DRM}$		4	
Typical tum-off time	t_q	$I_{TM} = 750\text{A}$; $dI/dt = -60\text{A}/\mu\text{s}$; $T_J = T_J$ maximum, $V_R = 50\text{V}$; $dV/dt = 20\text{V}/\mu\text{s}$; gate 0V ,100 Ω		200	

BLOCKING					
PARAMETER	SYMBOL	TEST CONDITIONS		VALUES	UNITS
Maximum peak reverse and off-state leakage current	I_{RRM} , I_{DRM}	$T_J = 125^\circ\text{C}$		40	mA
RMS isolation Voltage	V_{ISO}	50 Hz, circuit to base, all terminals shorted, 25°C, 1s		3500	V
Critical rate of rise of off-state voltage	dV/dt	$T_J = T_J$ maximum, linear to $V_D = 80\% V_{DRM}$		1000	$\text{V}/\mu\text{s}$

TRIGGERING					
PARAMETER	SYMBOL	TEST CONDITIONS		VALUES	UNITS
Maximum peak gate power	P_{GM}	$t_p \leq 5 \text{ ms}$, $T_J = T_J \text{ maximum}$		10	W
Maximum average gate power	$P_{G(AV)}$	$f = 50 \text{ Hz}$, $T_J = T_J \text{ maximum}$		3	
Maximum peak gate current	I_{GM}	$t_p \leq 5 \text{ ms}$, $T_J = T_J \text{ maximum}$		3	A
Maximum peak positive gate voltage	$+V_{GM}$			20	V
Maximum peak negative gate voltage	$-V_{GM}$			5.0	
Maximum required DC gate voltage to trigger	V_{GT}	$T_J = 25 \text{ }^\circ\text{C}$	Anode supply = 12 V, resistive load; $R_a = 1 \Omega$	2	mA
Maximum required DC gate current to trigger	I_{GT}			200	
Maximum gate voltage that will not trigger	V_{GD}	$T_J = T_J \text{ maximum}$, 67% V_{DRM} applied		0.25	V
Maximum gate current that will not trigger	I_{GD}			10	mA
Maximum rate of rise of turned-on current	di/dt	$T_J = T_J \text{ maximum}$, $I_{TM} = 400\text{A}$ rated V_{DRM} applied		1000	A/ μs

THERMAL AND MECHANICAL SPECIFICATIONS					
PARAMETER	SYMBOL	TEST CONDITIONS		VALUES	UNITS
junction operating and storage temperature range	T_J, T_{stg}			- 40 to 125	$^\circ\text{C}$
Maximum thermal resistance, junction to case per junction	R_{thJC}	DC operation		0.065	$^\circ\text{C/W}$
Typical thermal resistance, case to heatsink per module	R_{thCS}	Mounting surface, smooth , flat and greased		0.01	
Mounting torque $\pm 10 \%$ SMAP to heatsink , M6 busbar to SMAP , M10		A mounting compound is recommended and the torque should be rechecked after a period of about 3 hours to allow for the spread of the compound.		6 to 8	N.m
				12 to 15	
Approximate weight				1800	g
				63.5	oz.
Case style				SUPER MAGN-A-PAK	

ORDERING INFORMATION TABLE

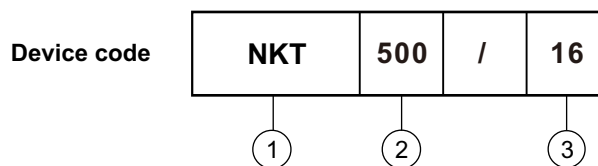

- 1 - Module type: NKT for (Thyristor + Thyristor) module
NKH for (Thyristor + Diode) module
NKET for single Thyristor module
- 2 - Current rating: $I_{T(AV)}$
- 3 - Voltage code x 100 = V_{RRM}

Nell High Power Products

Fig.1 On-state current vs. voltage characteristics

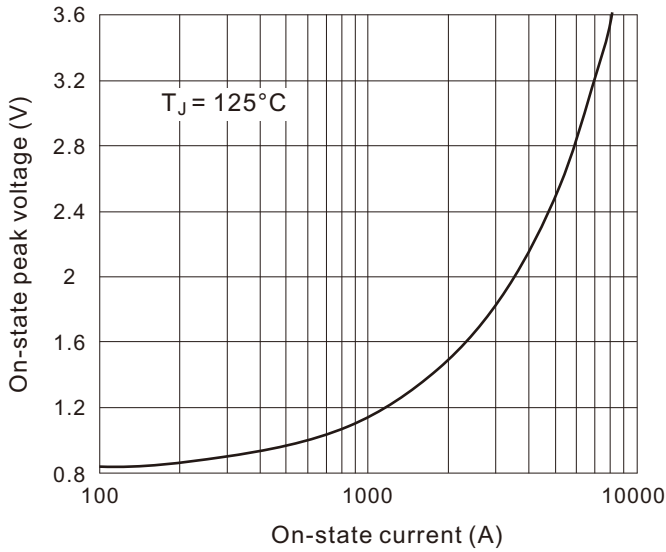

Fig.2 Transient thermal impedance(junction-case)

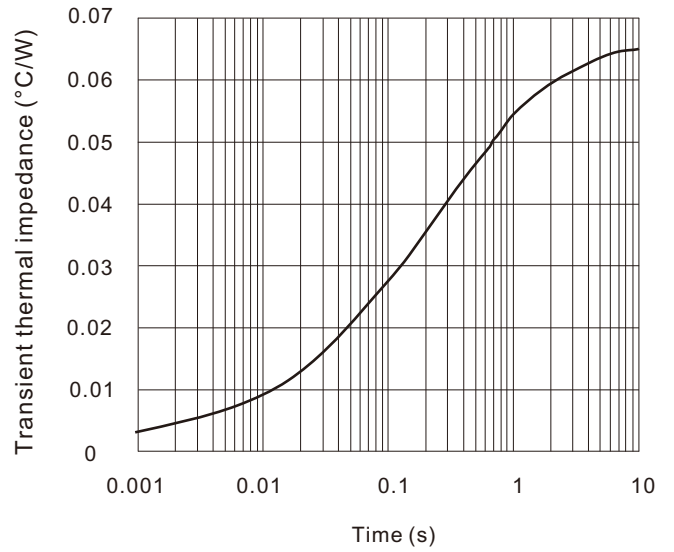

Fig.3 Power consumption vs. average current

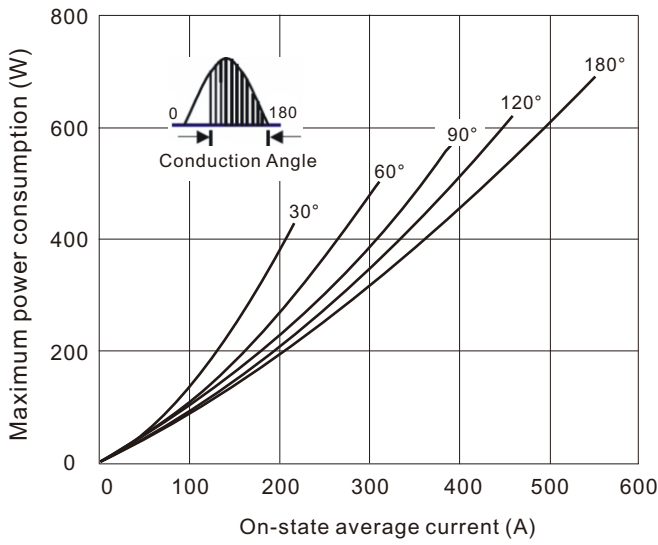

Fig.4 Case temperature vs. on-state average current

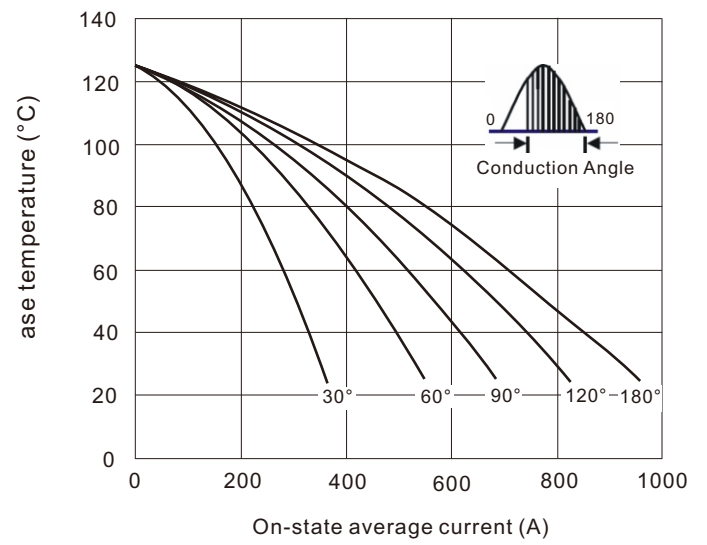

Fig.5 On-state surge current vs cycles

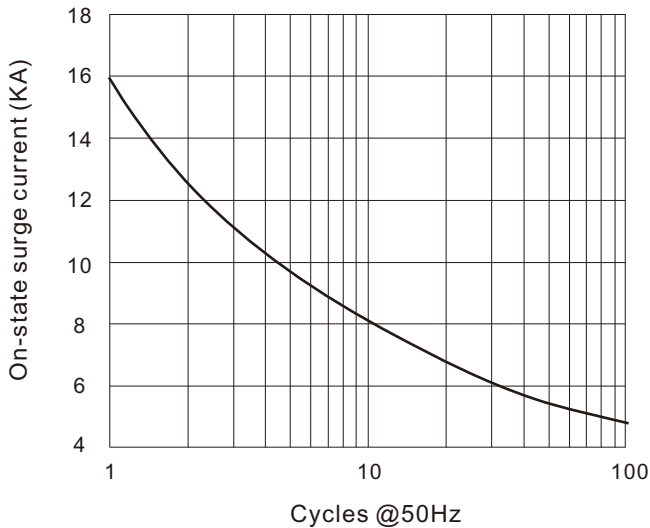

Fig.6 I^2t characteristics

