

Standard Recovery Diodes, 160 A (INT-A-PAK Power Modules)

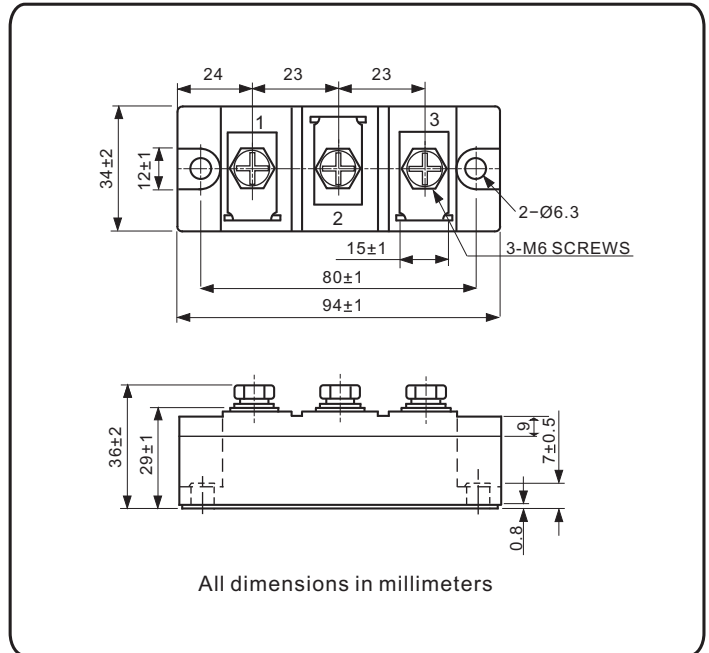

FEATURES

- High voltage
- Electrically isolated by DBC ceramic (Al_2O_3)
- 3000 V_{RMS} isolating voltage
- Industrial standard package
- High surge capability
- Modules uses high voltage power diodes in four basic configurations
- Simple mounting
- UL approved file E320098
- Compliant to RoHS
- Designed and qualified for multiple level

APPLICATIONS

- DC motor control and drives
- Battery charges
- Welders
- Power converters

PRODUCT SUMMARY	
$I_{F(AV)}$	160 A
Type	Modules - Diode, High Voltage



MAJOR RATINGS AND CHARACTERISTICS			
SYMBOL	CHARACTERISTICS	VALUE	UNITS
$I_{F(AV)}$		160	A
	T_C	100	$^{\circ}C$
$I_{F(RMS)}$		251	A
I_{FSM}	50 Hz	6000	
	60 Hz	6282	
I^2t	50 Hz	180	kA^2s
	60 Hz	164	
$I^2\sqrt{t}$		1800	$kA^2\sqrt{s}$
V_{RRM}		400 to 1600	V
T_J	Range	-40 to 150	$^{\circ}C$

ELECTRICAL SPECIFICATIONS

VOLTAGE RATINGS				
TYPE NUMBER	VOLTAGE CODE	V_{RRM} , MAXIMUM REPETITIVE PEAK REVERSE VOLTAGE V	V_{RSM} , MAXIMUM NON-REPETITIVE PEAK REVERSE VOLTAGE V	I_{RRM} AT 150 °C mA
NKD160 NKJ160 NKC160	04	400	500	8
	08	800	900	
	12	1200	1300	
	14	1400	1500	
	16	1600	1700	

FORWARD CONDUCTION						
PARAMETER	SYMBOL	TEST CONDITIONS		VALUE	UNITS	
Maximum average on-state current at case temperature	$I_{F(AV)}$	180° conduction, half sine wave		160	A	
				100	°C	
Maximum RMS on-state current	$I_{F(RMS)}$	180° conduction, half sine wave, 50Hz, $T_C = 100^\circ\text{C}$		251		
Maximum peak, one-cycle, on-state non-repetitive surge current	I_{FSM}	t = 10 ms	No voltage reappplied	Sine half wave, initial $T_J = T_J$ maximum	6000	A
		t = 8.3 ms			6282	
Maximum I^2t for fusing	I^2t	t = 10 ms	100% V_{RRM} reappplied		180	kA ² s
		t = 8.3 ms			164	
		t = 10 ms	126			
		t = 8.3 ms	115			
Maximum $I^2\sqrt{t}$ for fusing	$I^2\sqrt{t}$	t = 0.1 ms to 10 ms, no voltage reappplied		1800	kA ² √s	
Maximum forward voltage drop	V_{FM}	$I_{FM} = 480\text{A}$, $T_J = 25^\circ\text{C}$, 180° conduction		1.40	V	

BLOCKING					
PARAMETER	SYMBOL	TEST CONDITIONS		VALUES	UNITS
Maximum peak reverse and off-state leakage current	I_{RRM}	$T_J = 150^\circ\text{C}$		8	mA
RMS isolation Voltage	V_{ISO}	50 Hz, circuit to base, all terminals shorted, t = 1s		3000	V
		t = 60s		2500	

THERMAL AND MECHANICAL SPECIFICATIONS				
PARAMETER	SYMBOL	TEST CONDITIONS	VALUES	UNITS
Maximum junction operating temperature range	T_{Stg}, T_J		- 40 to 150	°C
Maximum thermal resistance, junction to case per junction	R_{thJC}	DC operation	0.23	°C/W
Maximum thermal resistance, case to heatsink per module	R_{thCS}	Mounting surface, smooth, flat and greased	0.09	
Mounting torque $\pm 10\%$	IAP to heatsink, M6 busbar to IAP, M6	A mounting compound is recommended and the torque should be rechecked after a period of 3 hours to allow for the spread of the compound. Lubricated threads.	4 to 6	N.m
Approximate weight			220	g
			7.8	oz.
Case style			New INT-A-PAK	

ORDERING INFORMATION TABLE

Device code	NKD	160	/	16	A
	①	②	③	④	
①	- Module type: NKD, NKJ and NKC for (Diode + Diode) module				
②	- Current rating: $I_{F(AV)}$				
③	- Voltage code $\times 100 = V_{RRM}$				
④	- Assembly type, "A" for soldering type				

Fig.1 On-state current vs. voltage characteristic

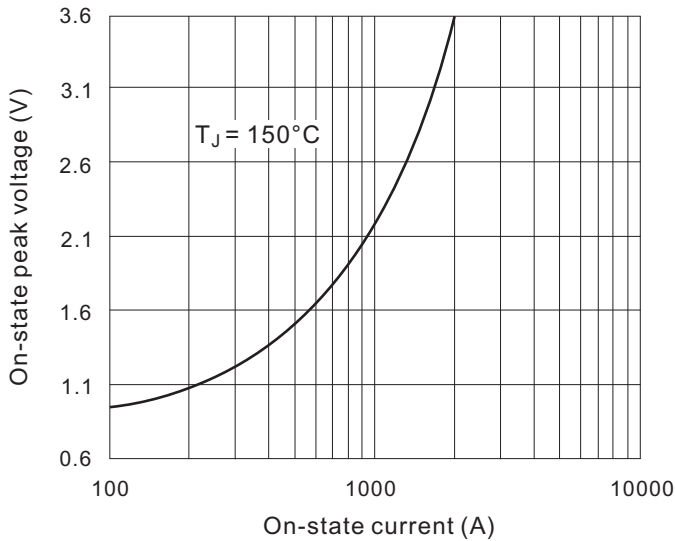

Fig.2 Transient thermal impedance(junction-case)

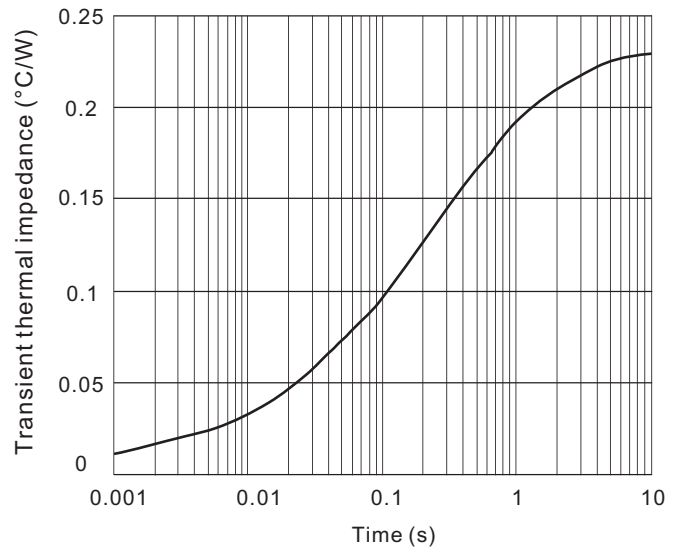

Fig.3 Power consumption vs. average current

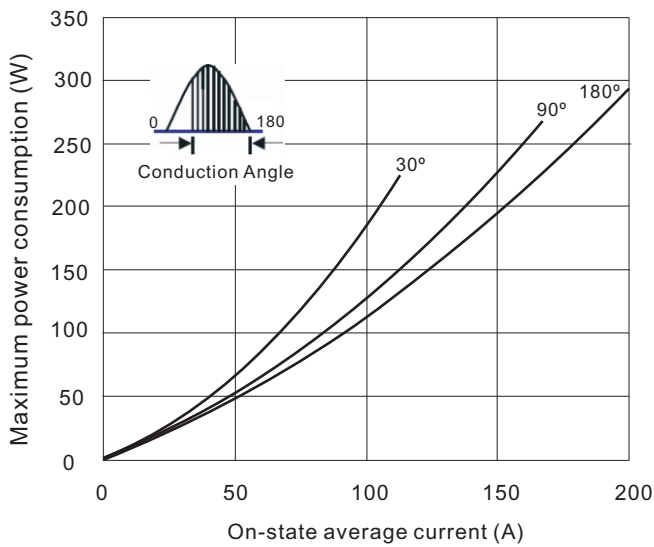

Fig.4 Case temperature vs. on-state average current

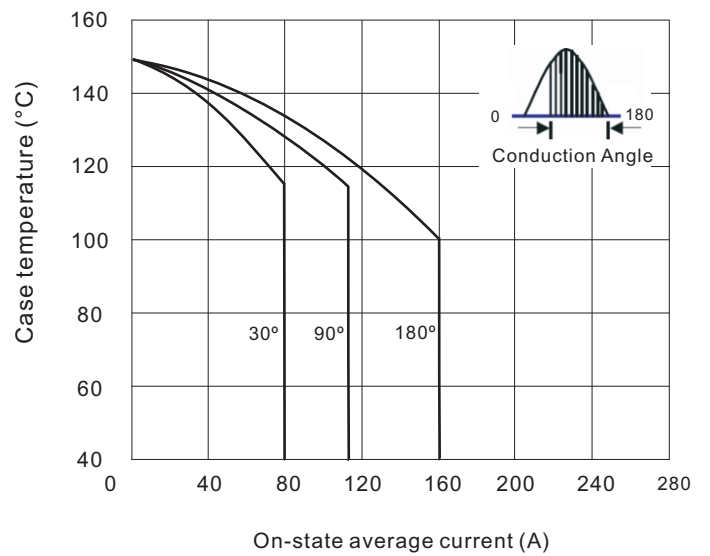

Fig.5 On-state surge current vs cycles

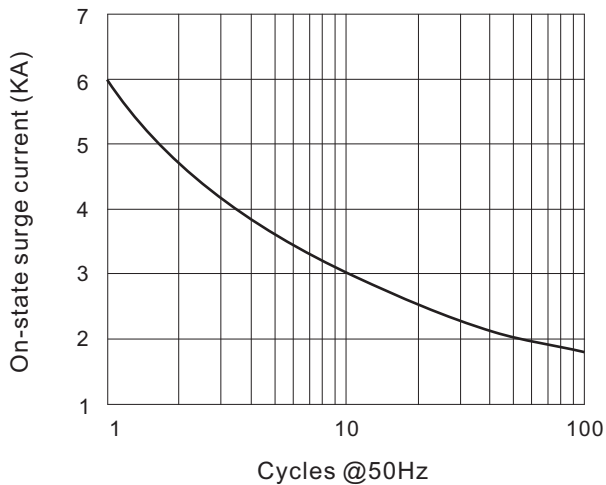

Fig.6 I^2t Characteristic

